

ideas make future

**ECU MASTER
CDI - TCI
V8.43**

Description

The product *ECU MASTER* is a brand new series of *ECU units*. Device based on experience in development of industrial and safety systems, ignition units and particularly our customers' needs which provided a foundation for the idea and realisation of the new model.

The *MASTER ECU* has been specially designed to control ignition advance or injection events for one to twelve cylinder combustion engines (depending on type). Any type of Trigger wheel and pick up sensor variant is possible, with features like 5D maps of advance and injection control, integrated pressure sensor, temperature, tachometer output, exhaust servo throttle, electronic accelerator pedal, engine speed and turbo pressure *PID* regulation, switching of fuel pump and support *CANbus - J1939 / OBD2* or *CANopen*.

The list of features mentioned allows the *MASTER ECU* range to be used either for a service or tuning replacement for production or vintage motorcycle and automobile *ECU* units, that require modified ignition or injection control. The integrated redundancy of sensing, together with other key features makes *MASTER ECU* suitable for marine, aviation and racing sport applications, and also is suitable for cogeneration units with fuel *LPG* or *CNG*.

All *MASTER ECUs* based on *FPGA* technology, which provides 1MSPS analog-digital conversion of the Pick up sensor signal, as well as its evaluation and calculation of the rotational mathematical model 64bit. Simultaneously, it deals with other operations i.e. redundancy sensing, total control of CDI converter, advanced features and signal records. *FPGA* technology is interesting not only for its high operating performance but particularly for its accuracy, which in principle microprocessor-based interrupt systems cannot achieve.

Main Features

- ✓ Supply voltage range from 3.5 to 36 V (depending on type)
- ✓ Engine speed range from 0 to 65 000 RPM
- ✓ Operating temperature -40 to 85 °C
- ✓ Based on *FPGA* technology and microprocessor support
- ✓ Mathematical model of the real engine rotation, math operation 64bit
- ✓ Adjustable pick up sensing levels, A/D conversion of signals, ± 25.5 V, 1MSPS
- ✓ Trigger wheel maps, pick up voltage levels for different engine speeds, filters capture
- ✓ Flexible pick up sensor inputs: Induction, Hall, Optical, Hammer, Proximity NPN/PNP
- ✓ Redundancy of sensing and other integrated elements
- ✓ Flexible ignition and injector control – optional 5D map of $\pm 360^\circ$ and 0 to 60ms
- ✓ Integrated pressure sensor -80 to + 150kPa (depending on type)
- ✓ Integrated oscilloscope, with realtime visualisation of pick up and output switching, 1MSPS
- ✓ Support *CANbus* in protocol SAE J1939 / OBD2 and *CANopen* (depending on type)
- ✓ Integrated *LAMBDA* controller - LSU 4.2 & LSU 4.9 or support SAE J1939 connection
- ✓ Coil outputs – MOSFET automotive – CDI, TCI or combined, 3 to 12 outputs
- ✓ Advanced functions – acceleration brake, temperature, pressure, servo control, *PID*
- ✓ Datalogger to internal flash 8MB – long-term records, engine hours, RPM, inputs and other
- ✓ Integrated and full control CDI converter 400V with superb performance of 100W
- ✓ User configuration by PC – while in operation with possibility of status visualization
- ✓ Galvanic isolated USB – common ground USB protection and EMC disturbance
- ✓ Measurement of supply voltage, temperature and load of CDI converters
- ✓ Users Firmware Upgrade – Free regular and easy updates via the website



Technical Parameters

Parameters	Range
Supply voltage	CDI (12V) ... 7 – 21V, TCI 6V ... 3.5 - 25V CDI (24V) ... 12 - 36V, MINI 3.5 - 25V TCI ... 7 - 36V, LITE 3.5 - 21V
Current consumption, ECU	CDI... 0-10A, dependent on the speed TCI... < 100mA
Working speed rate (range management)	0 - 65 000 rpm (0.1 - 65 000 rpm)
Working temperature	-40 to 85°C
Pick up (PA, PB)	±25.5V, ±0.1V, max ±100V, sampling 1Msp/s
Maps advance [1]...[8]	±360°, 8 x 256 pts, (0.1 - 65 000 rpm)
Maps injection [1]...[8]	0...60ms, 8 x 256 pts, (0.1 - 65 000 rpm)
Coil switching (10A, 10B, 10C ... 10V) 2x, 4x or 12x, CDI, TCI (depend on type)	MOSFET automotive 18A/650V OVERVOLTAGE protection 360V
Digital inputs (DI1, DI2, DI3, DI4)	0–2V =L, 3–16V =H (DI3,4 -Pull up 10kΩ)
Analog inputs (AI1, AI2, AI3, AI4, AI5)	AI1,AI2,AI5.. 0 - 5V; AI3,AI4.. 0-5V or 0-10kΩ
Digital outputs (DO1, DO2)	MOSFET BRIDGE 5A/40V (Pull up 1kΩ)
Stepper Motor (A+,A-,B+,B-)	1,5A, (extended, not for variant 12TCI)
Integrated pressure sensor (AI6)	-80 to 150kPa (tol. ± 4kPa) (by order type)
Measurement of voltage (power supply)	7 to 50V (tol. ±2%)
Measurement of temperature (inside)	-40 to +125°C (tol. ±2°C)
CDI converter (voltage, current, efficiency)	250-400V, 5-45A(pulse), efficiency 75%
Resistance of primary winding coils*	CDI - Capacitance, resistance 0.1 - 1.5Ω TCI* - Inductive, resistance 0.2 - 25Ω TCI* - Injection, resistance 0.2 - 25Ω
Communication (CANH, CANL)	J1939 / OBD2 / CANopen (extended type only)
Datalogger / Oscilloscope record memory	8MB FLASH / 8kB RAM (*.CSV record file)
Status indication by LED	Blue, Red
User configuration - USB	Freeware software MASTER control
Galvanic isolated USB	Common ground USB protection and EMC
Degree of protection	IP65
Package size	105x95x37mm or 105x148x37mm (extended) 120x67x25 mm (MINI) or 80x55x16 mm (LITE)
Weight	300g or 550g (extended), 225g (MINI), 100g (LITE)

* measured between terminal 1 and G (ground) for capacitive coil or 1 and + (supply) induction

* TCI - possibility for other use (switching, injector jets, fuel pump, stroboscope, speedometer etc.)

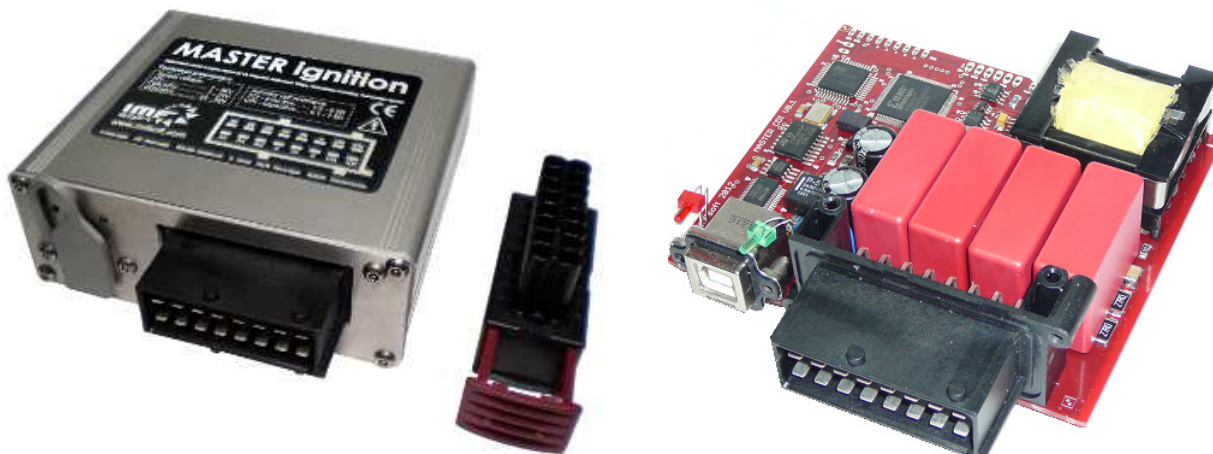

Connector wiring – MASTER front connector (aluminium case)

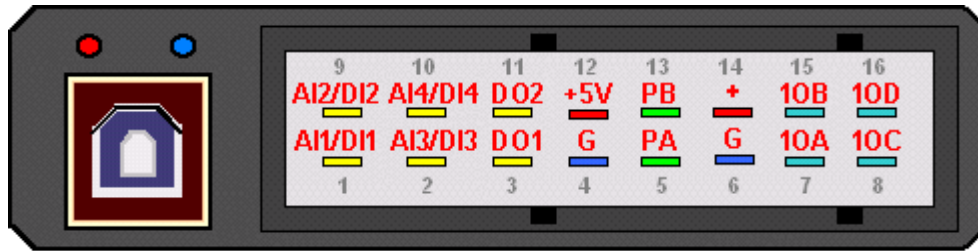

MARKING	DESCRIPTION	RANGE, ACTIVE LEVEL
+	Voltage supply	7 – 36V (12V) / 3.5 – 25V (6V)
G	Power ground Sensors ground	0V
10A-10D	Switching coils A-D or user output	CDI - Capacitance, resistance 0.1 - 1.5Ω TCI* - Inductive, resistance 0.2 - 25Ω (Pull up 1kΩ) TCI* - Injection, resistance 0.2 - 25Ω (Pull up 1kΩ)
+5V	Power sensors output	+5V, 100mA
PA, PB	Rotation sensor A,B	±25.5V, minimum ±0.1V, sampling 1MSPS
AI1.. AI4 / DI1.. DI4	Analog input AI1..4 Digital input DI1..4	AI1..AI2: 0-5V; AI3..4: 0-5V/ 0-10kΩ DI1..DI2: 0-16V; DI3..4: 0-16V (Pull up 10kΩ)
DO1, DO2	Digital output DO1..2	MOSFET BRIDGE 5A/40V (Pull up 1kΩ)

* TCI - possibility for other use (switching, injector jets, fuel pump, stroboscope, speedometer etc.)

Connector wiring – MASTER back connector (extended)

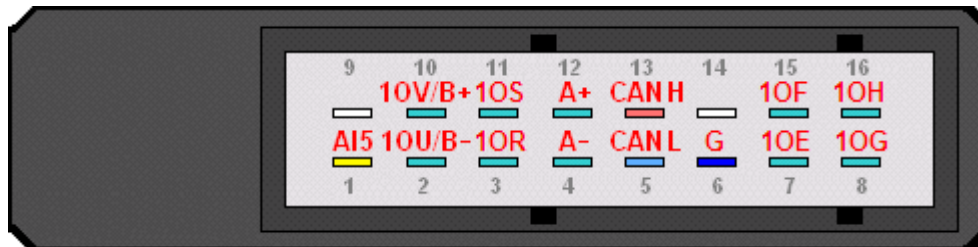

MARKING	DESCRIPTION	RANGE, ACTIVE LEVEL
G	Power ground Sensors ground	0V
CAN H CAN L	CANbus	J1939 / OBD2 and CANopen, 250kbps, 120R
10E-10V	Switching coils E-V or user output	CDI - Capacitance, resistance 0.1 - 1.5Ω TCI* - Inductive, resistance 0.2 - 25Ω (Pull up 1kΩ) TCI* - Injection, resistance 0.2 - 25Ω (Pull up 1kΩ)
AI5	Analog input AI5	AI5: 0-5V
A+,A-,B+,B-	Stepper Motor	1,5A, internal control by signal -10U, 10V

• TCI - possibility for other use (switching, injector jets, fuel pump, stroboscope, speedometer etc.)

Connector wiring – LAMBDA back connector (extended)

Please find in document LAMBDA controller (1002-0028-14)

Connector wiring – MASTER MINI (orange plastic case)

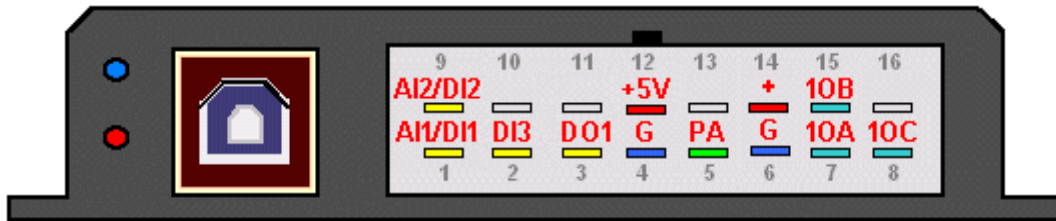

MARKING	DESCRIPTION	RANGE, ACTIVE LEVEL
+	Voltage supply	3.5 - 25V
G	Power ground Sensors ground	0V
10A-10C	Switching coils A-C or user output	TCI* - Inductive, resistance 0.2 - 25Ω (Pull up 1kΩ) TCI* - Injection, resistance 0.2 - 25Ω (Pull up 1kΩ)
+5V	Power sensors output	+5V, 100mA
PA	Rotation sensor A	±25.5V, minimum ±0.1V, sampling 1Mps
AI1, AI2 / DI1, DI2, DI3	Analog input AI1,2 Digital input DI1,2,3	AI1: 0-5V/ 0-10kΩ; AI2: 0-5V DI2: 0-16V; DI1,DI3: 0-16V (Pull up 10kΩ)
DO1	Digital output DO1	MOSFET 1A/100V (Pull up 1kΩ) - not in Bridge

* TCI - possibility for other use (switching, injector jets, fuel pump, stroboscope, speedometer etc.)

The MASTER MINI ECU compared with the MASTER ECU (metal case) has reduced inputs & outputs AI3, AI4, D4, PB, 10D. All software functions including injection support are maintained. When using the MASTER software choose **HARDWARE VERSION** → V7.X. Documentation at the bottom is however the same for all versions of MASTER ECUs!

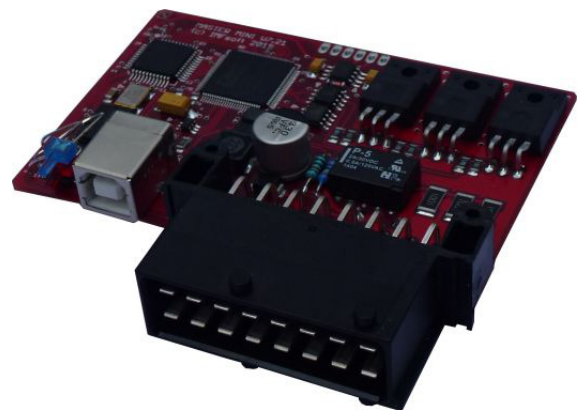

Connector wiring – MASTER LITE (aluminium case)

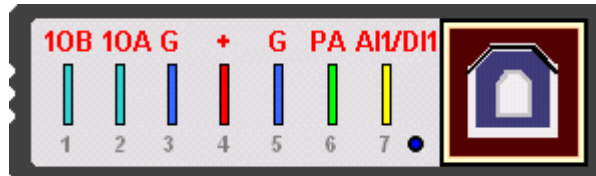

MARKING	DESCRIPTION	RANGE, ACTIVE LEVEL
+	Voltage supply	3.5 - 21V
G	Power ground Sensors ground	0V
10A-10B	Switching coils A-B or user output	TCI* - Inductive, resistance 0.2 - 25Ω (Pull up 1kΩ) TCI* - Injection, resistance 0.2 - 25Ω (Pull up 1kΩ)
PA	Rotation sensor A	±25.5V, minimum ±0.1V, sampling 1Mps
AI1 / DI1	Analog input AI1 Digital input DI1	AI1: 0-5V/ 0-10kΩ; DI1: 0-16V (Pull up 10kΩ)

* TCI - possibility for other use (switching, injector jets, fuel pump, stroboscope, speedometer etc.)

The MASTER LITE ECU compared with the MASTER ECU (metal case) has reduced inputs & outputs AI2,AI3,AI4,DI2,DI3, DI4, PB,10C,10D,DO1,DO2. All software functions including injection support are maintained. When using the MASTER software choose HARDWARE VERSION → V7.X.

Documentation at the bottom is however the same for all versions of MASTER ECUs!

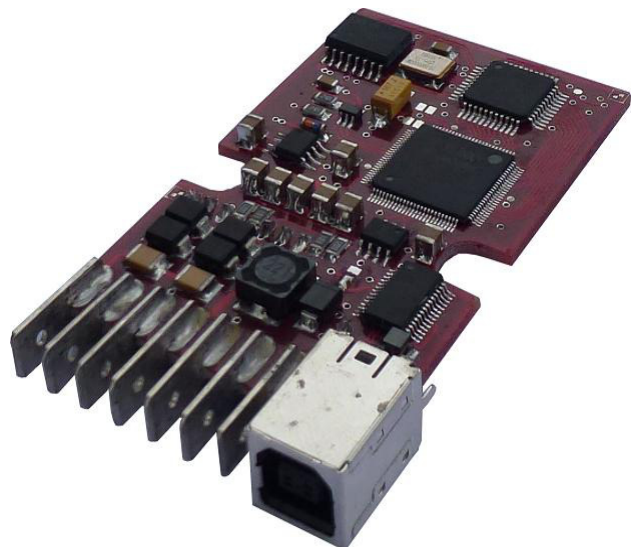

ECU MASTER - variants



Delivery time 3-5 days

ECU MASTER LITE – 2TCI	- 2x TCI outputs, 3.5 – 21V (HALL/ INDUCTIVE)
ECU MASTER MINI – 3TCI	- 3x TCI outputs, 3.5 – 25V
ECU MASTER – 4TCI – 6V	- 4x TCI outputs, 3.5 – 25V
ECU MASTER – 4TCI	- 4x TCI outputs, 7 – 36V
ECU MASTER – 10TCI	- 10x TCI outputs, 7 – 36V
ECU MASTER – 12TCI	- 12x TCI outputs, 7 – 36V
ECU MASTER – 1CDI 3TCI – 12V	- 1x CDI outputs, 3x TCI outputs, 7 – 21V
ECU MASTER – 2CDI 2TCI – 12V	- 2x CDI outputs, 2x TCI outputs, 7 – 21V
ECU MASTER – 3CDI 1TCI – 12V	- 3x CDI outputs, 1x TCI outputs, 7 – 21V
ECU MASTER – 4CDI – 12V	- 4x CDI outputs, 7 – 21V
ECU MASTER – 4CDI 6TCI – 12V	- 4x CDI outputs, 6x TCI outputs, 7 – 21V
ECU MASTER – 5CDI 5TCI – 12V	- 5x CDI outputs, 5x TCI outputs, 7 – 21V
ECU MASTER – 6CDI 4TCI – 12V	- 6x CDI outputs, 4x TCI outputs, 7 – 21V
ECU MASTER – 10CDI – 12V	- 10x CDI outputs, 7 – 21V
ECU MASTER – 2CDI 2TCI – 24V	- 2x CDI outputs, 2x TCI outputs, 12 – 36V
ECU MASTER – 4CDI – 24V	- 4x CDI outputs, 12 – 36V
ECU MASTER – 4CDI 6TCI – 24V	- 4x CDI outputs, 6x TCI outputs, 12 – 36V
ECU MASTER – 6CDI 4TCI – 24V	- 6x CDI outputs, 4x TCI outputs, 12 – 36V
ECU MASTER – 10CDI – 24V	- 10x CDI outputs, 12 – 36V

Variant with integrated PRESSURE sensor is marked by next symbol – P

Variant with integrated LAMBDA controller is marked by next symbol – L

Outputs TCI is possible to produce as inverted (need for coils with integrated transistor)

Feature of CDI and TCI outputs



Output feature	CDI - capacitance	TCI - inductive
Energy efficiency	+++	+
Energy of spark	+++	+++
Spark slope	+++	+
Low coils weight	+++	-
Difficulty of construction	-	+++
Another use of output*	-	+++

* Possibility for other use (switching, injector jets, fuel pump, stroboscope, speedometer etc.)



Installation

Electronic spark ignition unit *ECU MASTER* is powered by safe voltage up to 36V, but there is present a voltage of thousands of volts on ignition coils!!! Therefore, it is necessary to pay maximum attention when manipulating. Any changes to the electrical installation of ignition cannot be carried on unless the power is off!!!

Power supply and all ignition inputs are protected against overvoltage and reverse polarity. Neither overvoltage status nor reverse polarity can last permanently, as it can overload the security elements and cause partial or complete damage to the functionality of the ignition.



Ignition outputs are not protected against short circuit and therefore outputs from 10A up to 10V, DO1 or DO2 must not be connected to the power terminal (+). Connection to impedance is also forbidden as it would exceed the amount of allowed current and result in overload and following destruction of certain switching elements in the ignition.

Spark plug together with cylinder head and engine block must be connected to negative or positive pole of the power. This is necessary to flow of current from secondary winding of ignition coils.

Aluminium housing if ignition is due to own shielding connected to negative pole. Therefore no other conductor apart from negative pole can be connected to the housing.

Ignition must never be installed at the places with direct exposure to water, chemicals, extreme temperatures and vibrations. The effect of any of these may cause irreversible damage or destruction of ignition functionality.



The correct and reliable function of installed equipment is based on its correct power supply. Power wires (+, G) must have a diameter of 1.5 mm², which is ideal for CDI variant. Variant TCI must follow this condition only in case of ground wire (G). Power supply must always be done through fuse 10A, which protects ignition in case of reverse polarity, overvoltage or other disorders.

Sparks must be provided with shielding caps and ideal use cable with a carbon core. The signal conductor from the rotation sensor cannot be lead in parallel way with excitation coil wire (10A to 10V), high-voltage conductors or conductors of the alternator excitation. If it is not possible to carry out the wiring in this way it is recommended to lead signal conductor sensors (PA, PB) in twisted (twisted in pair) or shielded conductors in order to eliminate any possible interference of electric-installation.

Connectors crimping

Connector crimping requires a similar procedure as with FASTON connectors, although there is a rubber sealing grommet used here in addition. Regarding tool, it can be done with standard crimping pliers FASTON 1.5mm – 2.5mm. For blocking of unused terminal connectors TYCO it is appropriate to use supplied rubber plugs to comply with IP65 degree of protection.

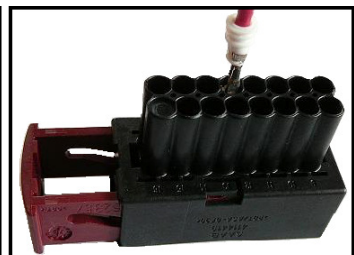
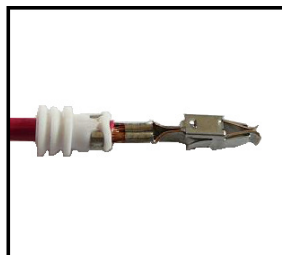
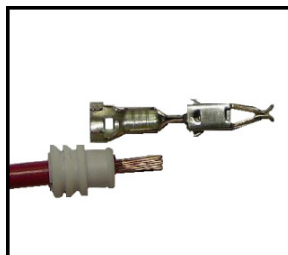

Connection diagram

CDI – model showing connecting of sensor PA and one output 10A

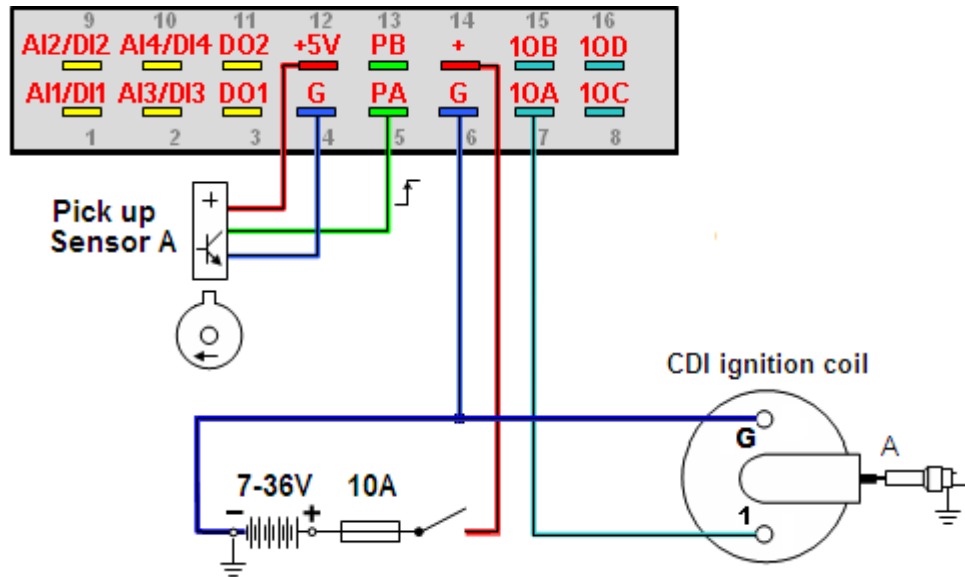

+ ... Positive power supply +5V ... Sensor power supply 10A.... Switching capacity coil
 G ... Minus (Ground) PA ... Signal of Pick up sensor A

TCI – model showing connecting of sensor PA and one output 10A

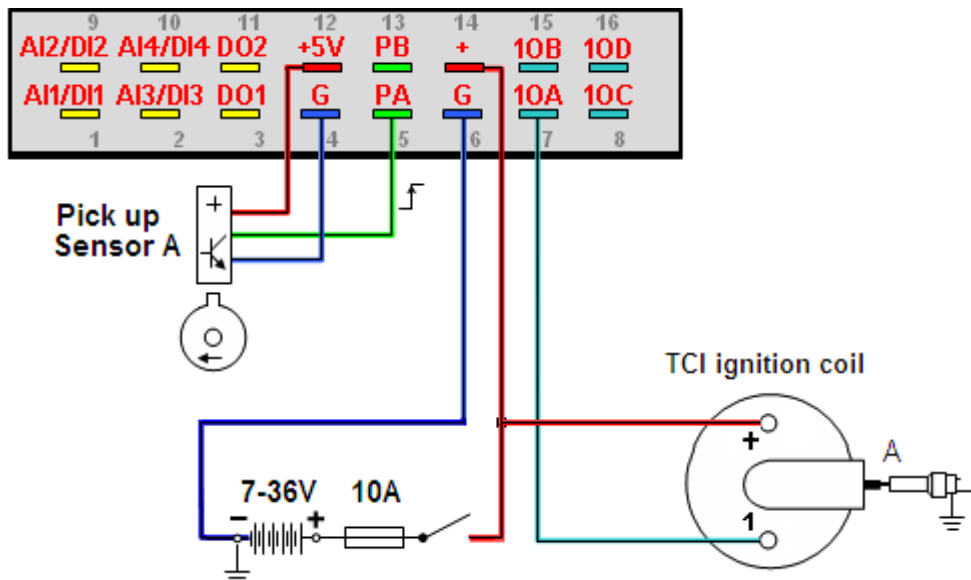

+ ... Positive power supply +5V ... Sensor power supply 10A.... Excitation of induction coil
 G ... Negative (Ground) PA ... Signal of Pick up sensor A

More diagram please find in document MASTERSchemeV8_xx_EN (1003-0018-12)

Pick up sensors PA, PB connection

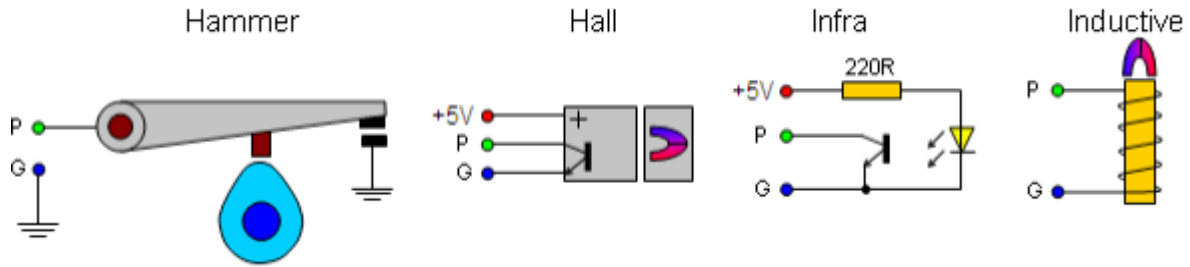

Analog inputs AI1, AI2, AI3, AI4

It is possible to connect sensors whose output is either voltage or resistance to analog inputs AI1, AI2, AI3 and AI4, where AI1, AI2 works with voltage 0-5V and AI3, AI4 works with voltage 0-5V or resistance 0-10kΩ. Signal from analog sensors should be lead by Twisted or shielded cable, which helps significantly to eliminate interference.

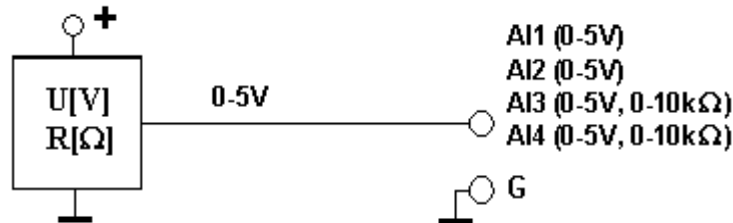

Digital inputs DI1, DI2, DI3, DI4

Change of input status DI3 and DI4 is easily done by input earthing or Bat. supply DI1, DI2.

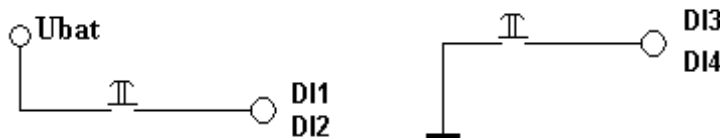

Digital outputs DO1, DO2

Digital outputs can be used for load switching to zero or to supply with maximum current load 5A. Therefore it is possible to connect e.g. relay coil, fuel pump, servo control, indicator of shift revolutions, stroboscope etc.

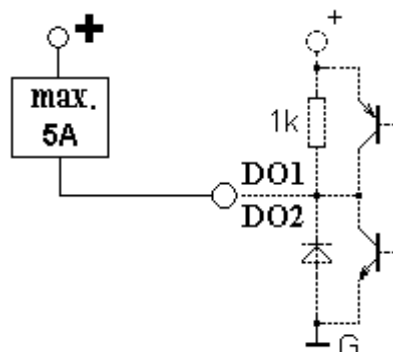

MASTER control – Freeware configuration software

Unless the configuration for a particular installation has not been done by the manufacturer then it is necessary to adjust the function of the ignition unit. Configuration is done through a personal computer from *MASTER-control* application via *USB connection*. The application is compactable with *Windows 95, 98, ME, NT, XP, VISTA, WIN7, WIN8, WIN10* or higher. The installation requires 4MB of free space on your hard disk.

Driver for USB is a standard part of Windows, or is also on the installation CD.

Making changes to the configuration such as reading and writing of parameters requires installation of application *MASTER-control*, power supply (+, G), *USB connection* and *COM Port* selection. When power supply is on it is indicated by flashing *blue LED*, data transfer is indicated by flashing red LED.

Rapid trial changes in the configuration of ECU MASTER can be made only temporarily by writing them into RAM memory or permanently by storing them in FLASH memory. After starting the application in order to avoid unwanted permanent rewrites is RAM memory selected permanently.

Examples of configurations are part of installation CD.

Application function



Opening configuration



Saving configuration



Information



Help



Online visualisation



Maps of advance



Advanced features



Sensor configuration



Starting visualisation



Reading configuration



Record configuration



Other settings



Selecting RAM



Selecting FLASH



Local help



Switching In-Out



Selecting Advance



Selecting Injection



Oscilloscope record



Acceleration Brake



Engine Stop



Password Lock ECU



Online visualisation

This is an operational display of function and status of ignition unit *MASTER*. In order to have functional display it is necessary to have USB connection and switch power supply on.

Visualised data

- Engine speed (rpm), advance of engine [°], injection time [ms], engine load [°]
- Pick up sensor voltage PA, PB [V]
- Power supply [V] and Temperature [°C]
- Converter CDI – Voltage [V], pulsed current [A] and load [%]
- Output signals 10A – 10V, DO1, DO2
- Input signals DI1 – DI4, AI1 – AI6
- Lambda value [-] and temperature [°C]
- Engine work time record [h:m:s]



Starting visualisation

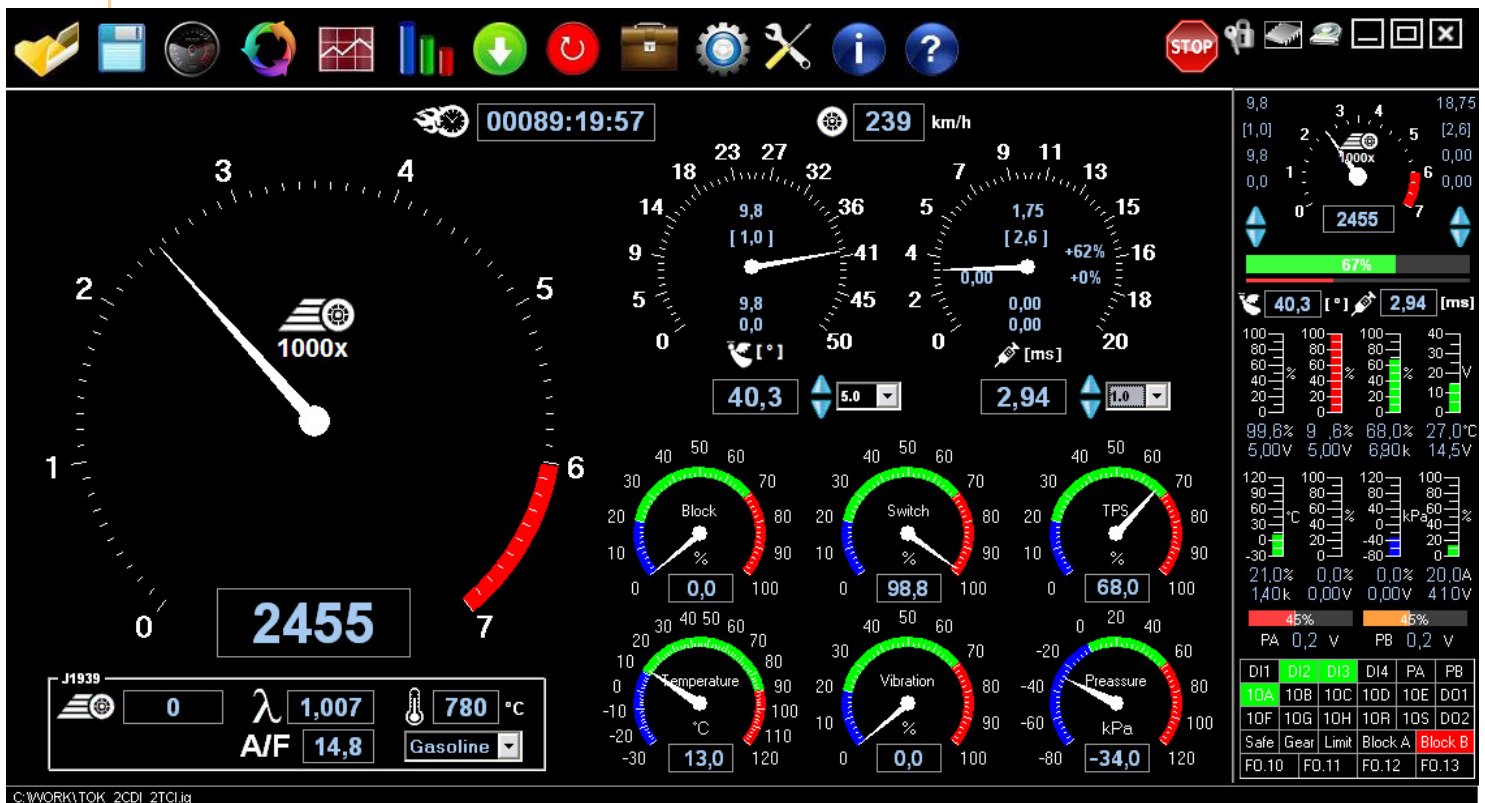

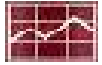

Oscilloscopic record

Oscilloscopic record is used in order to graphically visualise measured and calculated data. This helps to quickly evaluate the proper and accurate function of ignition unit *MASTER*. It can thus evaluate the correctness of voltage sensing, counting teeth of mathematic model of real rotation and angels of switching output coils.

An example to be given; curve angle of engine angular rotation must be regularly and horizontally increased from 0 to 360°. If there is any change of steepness in the curve or the angle is shorten, the problem is to be found either in wrong angle value set up, number of teeth, the type of synchronisation or unsuitable voltage for sensing.

Visualised data

- Pick up sensor voltage, PA, PB [V]
- Tooth index of pick up Trigger wheel, Tooth index A-B [-]
- Engine rotation, Angle A-B [°]
- Engine speed, Speed A-B [%]
- Outputs switching 10A-10V [-]

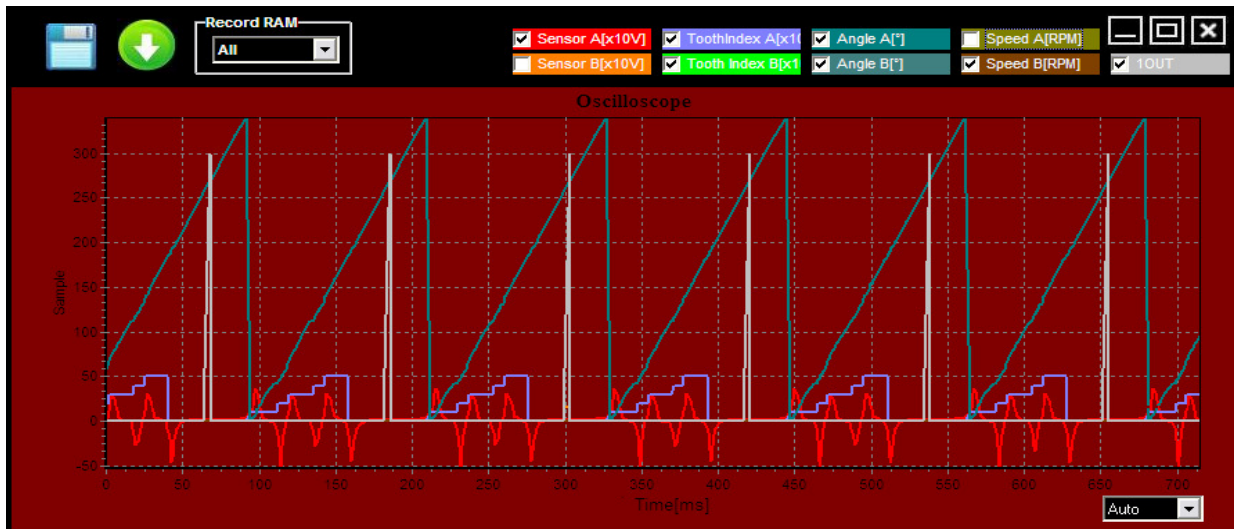
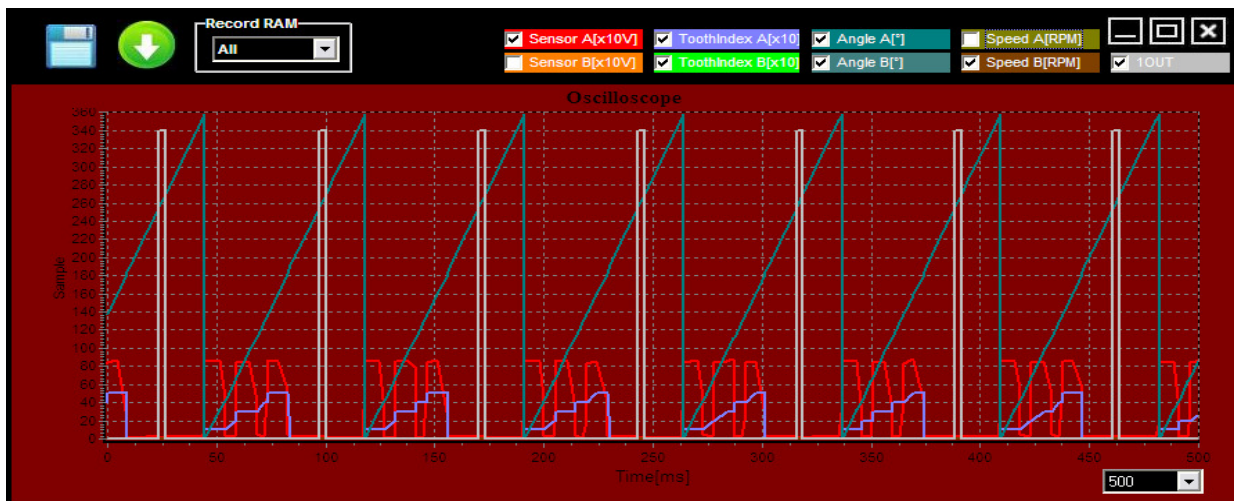

In this example, red colour refers to progress of voltage of sensor PA type HALL and INDUCTIVE, which scans three teeth 0-90-180° and in angle 270° 10A output is switched – grey curve. Blue colour represents teeth (edge) counting and the last curve refers to spinning of engine within the range of 0-360°.



Maps of Advance and Injection

Maps provide a fast tool to display and model individual curves in advance [1] – [8] in full angle range $\pm 360^\circ$ (Advance) and 0..60ms (Injection). The given figure influences the moment of output switch from 10A to 10V. By using digital DI1- DI4 or Analog outputs AI1- AI6, PA, PB it is possible to operationally switch among the maps.

Modelling tools

- Editor maps – quick draw of maps according to specified points
- Mouse modelling – direct editing of maps is possible by mouse movement
- Map shifting – whole map shifting or selected parts only
- Copying – copies of maps one to another of your choice
- Table – direct entry of specific points into table
- Filter – in-progress filtration, rounding the edges of maps

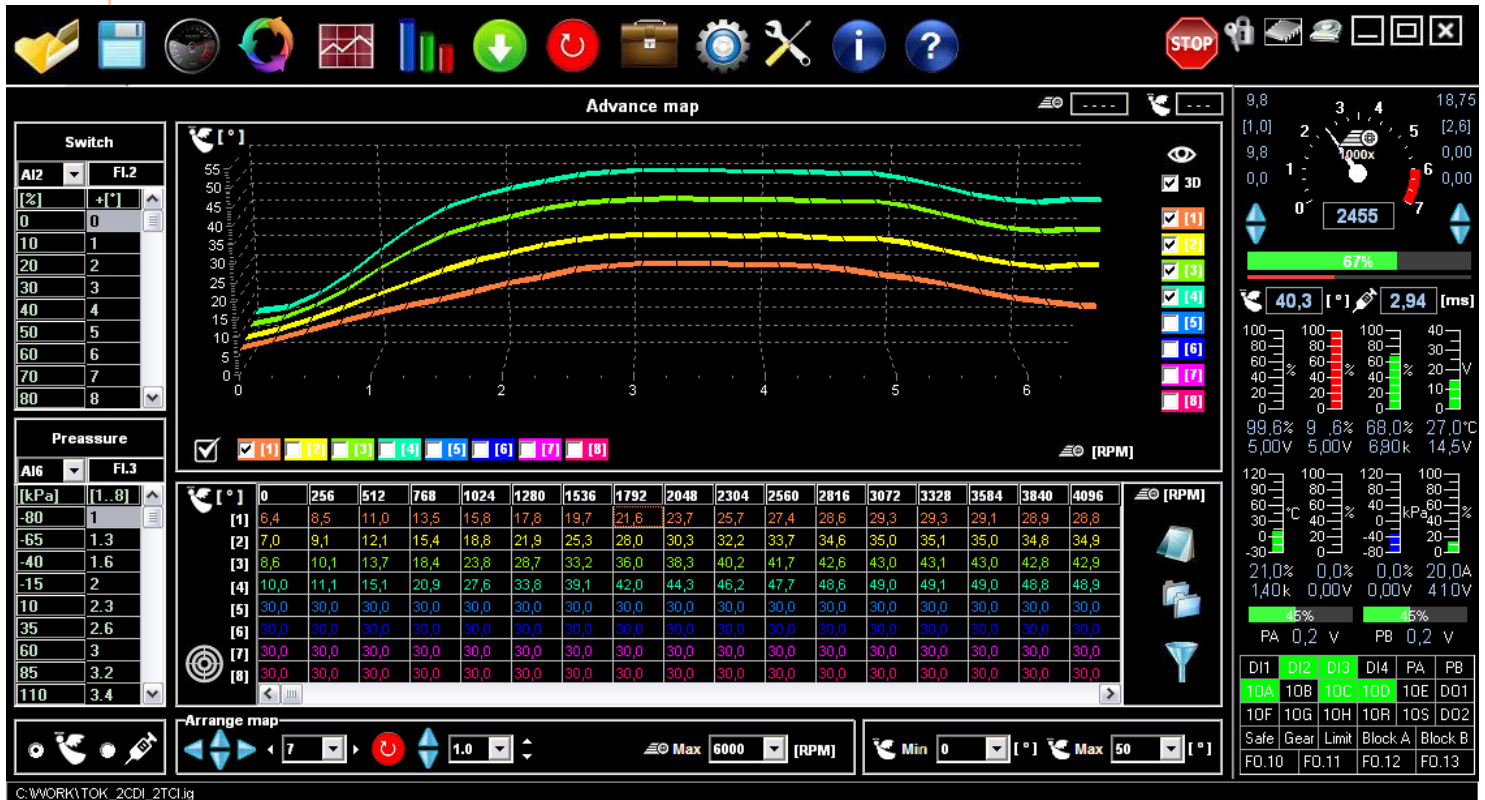



Pick up - sensor configuration description

A) Choosing type of sensor

Pick type

Internally it is decided whether to connect signal resistance to ground by Pull Down or Pull Up.

- Induction - signal load resistance switch internally Pull Down to clamp G
- Hall - signal supply resistance switch internally Pull Up to voltage 10V
- Opto - signal supply resistance switch internally Pull Up to voltage 10V
- Hammer - signal supply resistance switch internally Pull Up to voltage 10V

B) Points of sensing

Entering the number of samples allows obtaining valid evaluation of tooth edge. Entering allows filtering off interfering pulse, which prohibits the correct evaluation of teeth. Suitable value is between 2-7.

C) Entering of voltage levels

It is possible to enter one or more levels of voltage sensing depending on engine revolutions.

RPM	H (V)	PA (V)	L (V)	PB (V)
0	0.5	-0.5	0.5	-0.5
600	1.9	-1.9	1.9	-1.9
2500	2.7	-2.7	2.7	-2.7

- RPM - Entering revolutions from which entered levels of sensing are valid.
- Tooth H[V] - Entering voltage level for tooth H (increasing voltage), range $\pm 25.5V$
- Tooth L[V] - Entering voltage level for tooth L (decreasing voltage), range $\pm 25.5V$

Whereas, entered voltage level Tooth H[V] must be higher than Tooth L[V]

For sensing of HALL or OPTO it is usually sufficient to use one value only for the whole revolution range, thanks to easy switching of Pull Up resistance e.g.

Tooth H = 5.0V and Tooth L = 1.9V

For inductive sensing it is important to distinguish voltage for starting and basic operational speed e.g. for start choose Tooth H = 1.0V and Tooth L = -1.0V and for idle motion enter values Tooth H = 1.9V and Tooth L = -1.9V, it is also possible to increase the value according to the nature of sensor.

D) Synchronisation of teeth sensing MODE



From the perspective of teeth arrangement it is necessary to choose one from three types of modes of synchronisation:

- 1,2. Without synchronisation – engine rotation is determined by two edges only or for more edges where it is not necessary to divide pulses to individual outputs 10A to 10V.
3. Long space – synchronisation of rotation, thus determining the first tooth (edge) is made on the basis of a long space.
4. Short space – synchronisation of rotation, thus determining the first tooth (edge) is made on the basis of a short space.

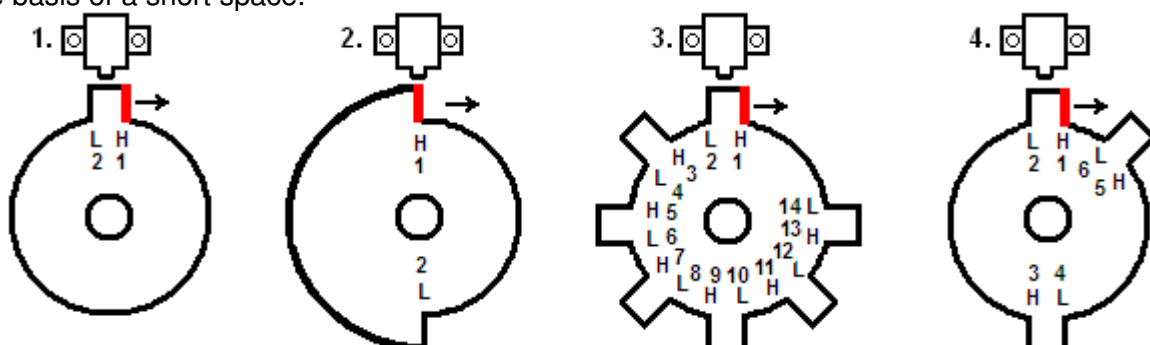

E) Entering angles of teeth edges

Edge [H/L]	Angle[*]
H	0
L	30
H	60
L	90
H	120
L	150
H	180
L	210
H	240
L	270

For a real evaluation of the motor shaft rotation it is necessary to enter a real map of teeth in format of edge angles. You can chose any of predefined Trigger wheel teeth maps Eg. BOSCH 60-2, BOSCH 36-2, BOSCH 2+1, BMW 36-1, FORD 36-1, SUZUKI 24-2, YAMAHA 16-2, HARLEY 32-2.

You can set your private maps of teeth. The accuracy of entering can be easily verified by oscilloscope record while engine in rotation, when a linear curve of engine rotation must be drawn within the range 0 - 360°. Common shifting of teeth angle can be done by entering the value correction PA and PB within range ±360°.

F) Entering angles of cylinders

Entering angles of cylinders is done in “Advanced features” – “output switching”

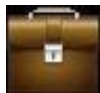

Advanced features



Switching to table of output switching

Table functions of outputs

For items from X1 to X10 functions FO.1 for CDI and FO.2 for TCI insert angles of cylinders from 10A to 10V and for items XTIME insert period of output switching. Switching time for the CDI is suitable 500us and for TCI from 1 to 5ms depending as the primary coil resistance. Switching time for the Injection coils is creating by Maps of Injection.

In order to determine the output being used it is necessary to choose output switching function.

Index	Function Name	Description	XA	XB	XC	XD	XE	XF	XG	XH	XR	XS	XTIME	10A	10B	10C	10D	10E	10F	10G	10H	10R	10S
FO.1	Capacitive - CDI	XA=out angle 10A..XS=10S,XTIME=switch[us]	0	120	240								300	FO.1	FO.1	FO.1	- - -	FO.3	FO.3	FO.3	- - -	- - -	- - -
FO.2	Inductive - TCI	XA=out angle 10A..XS=10S,XTIME=excit[ms]																					
FO.3	Injection Coil	XA= injection angle 10A..XS=10S					90	210	330														
FO.4	Integrate Coil	XA=out angle 10A..XS=10S,XTIME=switch[us]											300										
FO.5	Speed switch	XA=off speed, XTIME=switch time[s]	1000										0										
FO.6	Speedometer	XA=speed correction..XS																					
FO.7	Starter	XA=mode, XTIME=switch time[s]																					
FO.8	Fuel pump	XA=off speed, XTIME=start time[s]																					
FO.9	Strobe lamp	XA=switch angle, XTIME=light time[us]	0										50										
FO.10	Speed regulation	XA=mode, XB=RPM, XC=PWM, XE..XH = PID	0	1000	100		20	18	2	5													
FO.11	Turbo regulation	XA=mode, XB=RPM, XC=PWM, XE..XG = PID																					
FO.12	Charge regulation	XA=mode, XB=desired voltage, XC=PWM																					
FO.13																							



Advanced features

Configuration of advanced features gives possibility to sense temperature, pressure and other signals with opportunity to influence operational attributes of ignition unit. Regarding input signals, digital DI1-DI4 can be used or from Analog AI1-AI6, PA or PB can be used.

From operational and internal status, depending on selected function, output signals can be switched. Output signals are marked from 10A to 10V, DO1 and DO2.



Switching between the table input/output



Local help

Entering functions

- Option input FI.1 – FI.16 or output from FO.1 to FO.2
- Entering parameters of chosen function from XA to XV
- Choosing of input/output function and inversion of signal
- Description of function you can see in Local help



Input - setting of function

Index	Function Name	Description	X0	X1	X2	X3	X4	X5	X6	X7	X8	X9	X10
FI.1	Pick up	X0=offset PA, X1=offset PB <-+360>	-40										
FI.2	Advance Moving	X0=advance move ...X10 <-+360>	0	1	2	3	4	5	6	7	8	9	10
FI.3	Advance Maps	X0=advance map index ...X10 [1-8]	1	1.3	1.6	2	2.3	2.6	3	3.2	3.4	3.7	4
FI.4	Injection Moving	X0= injection time move ...X10 [-+ms]	-1	-1	0	0	0	0	2	5	10	15	20
FI.5	Injection Maps	X0= injection map index ...X10 [1-8]	1	1,2	1,5	1,7	2	2,2	2,5	2,7	3	3,2	4
FI.6	Overspeed	X0=overspeed											
FI.7	Starter	X0=mode of function											
FI.8	Blocked Run	X0=mode of function	0										
FI.9													
FI.10	Speed regulation	X0=initiate value [%]	20										
FI.11	Turbo regulation	X0=desired pressure [kPa]											
FI.12													
FI.13													
FI.14	Advance Debug	X0=advance move ...X10 <-+360>	0	1	2	3	4	5	6	7	8	9	10
FI.15	Injection Debug	X0= injection time move ...X10 [-+ms]	-2,5	-2	-1,5	-1	-0,5	0	0,5	1,0	1,5	2,0	2,5
FI.16													

Pick up angle position - correction due to the rotation disc with tooth
 The entered value is identical with the item "Offset PA" and "Offset PB", mutually copy
 Eg: X0=PA=0°, X1=PB=180°
 X0=Pick up PA position - offset PA <-360,+360>[°]
 X1=Pick up PB position - offset PB <-360,+360>[°]

Real-time Data:
 2455 (1000x)
 67%
 40,3 [°] 2,94 [ms]
 99,6% 9,6% 68,0% 27,0°C
 5,00V 5,00V 6,90k 14,5V
 120 100 120 100
 60 80 60 80
 30 40 20 40
 0 0 0 0
 -30 0 -80 0
 21,0% 0,0% 0,0% 20,0A
 1,40k 0,00V 0,00V 4,10V
 PA 0,2 V PB 0,2 V
 DI1 DI2 DI3 DI4 PA PB
 10A 10B 10C 10D 10E DO1
 10F 10G 10H 10R 10S DO2
 Safe Gear Limit Block A Block B
 FO.10 FO.11 FO.12 FO.13

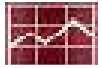

Acceleration brake

Acceleration brake is a function for a measure, calculating and visualisation of actual engine power [\sim kW] and torque [\sim Nm] solved from the engine acceleration value. When engine accelerates then is used the mass of flywheel as the brake. By the use of acceleration brake can be verified the behavior of the engine throughout the rev range for different advance setting, injection time or other characteristics affecting the behavior of the engine. The measured data and calculated power and torque are only proportional to the actual value, it is not a measurement of real values kW of Nm. These informations can be used only for comparison engine behavior for different ignition settings.

Using of acceleration brake

- Open Oscilloscope window and select *Brake* in menu *Record RAM*.
- Accelerate engine from low to high speed repeatedly 2x .. 7x in sequence
- Click to button for a read and show













Visualised data

- Power [\sim kW]
- Torque [\sim Nm]



Installation Step by Step

1. Install *MASTER control* application on a personal computer with *Windows OS* such as: *95 / 98 / ME / NT / XP / Vista / WIN7 / WIN8 / WIN10*
2. Make a connection to *ECU MASTER* by cable *USB A-B*, with a personal computer and install the *USB driver*. Under *WIN 7 / WIN 8 / WIN10* is installed automatically. After connecting the USB cable is automatically created a new COM port, enter this number in the application menu to Port item. 
3. Connect the power wires to the ignition '+' and 'G' (12V or 24V) only. Once connected, briefly flashes red "SW Boot" and 2 seconds later, the flashing blue LED.
4. Connect the wires of pick up sensor '*PA*', '*G*' and '*+5V*' or (*PB*)
5. Run *Online visualisation* and verify the function of sensing - voltage change of *PA (PB)* during the tooth passes around the pick up sensor . 
6. Open example configuration *ECU MASTER* according to the application: **Example_TCI.ig**, **Example_CDI.ig**, or **Example_Injection.ig** or another for a particular engine or application. 
7. Make adjustment of pick sensor settings teeth according to their actual distribution 
8. Make correction or completion of outputs switching angles, but the wires just donot connect yet 
9. Make eventual correction advance or injection maps 
10. Load configuration into the *ECU MASTER* unit to FLASH or RAM memory, according to the needs of permanent or temporary storage.   
11. Run the starter of engine or otherwise run, and let it read oscilloscop record, to verify the function of the rotation pick up sensor and correct switching outputs angles 
12. Connect the outputs as needed:
10A,10B,10C,10D,10E,10F,10G,10H,10R,10S,10U,10V
to capacitive, inductive or injection coil or other devices
13. If you find a problem, please use the file **MasterFAQ_EN.pdf** (1003-0019-12)
14. For additional help, you can use the contact>: support@imfsoft.com